



ASGARD INDUSTRIAL SYSTEMS LTD.

Radiant Heating.

The HCP range of Low Pressure Hot Water (LPHW) radiant heating panels offers an efficient and low maintenance solution to space heating requirements.

Radiant heaters increase the temperature of objects and people rather than the temperature of the air. Imagine the warming effect of the sun's rays when revealed from behind a cloud – you feel warmer, but the air temperature remains the same.

Because of this HCP's radiant heating products offer instant and cost-effective heating. There are also minimal maintenance requirements associated with these products, which is very important as more and more professionals are considering the whole-life cost of a project.

Benefits compared to other heating methods include reduced air and dust movement (leading to less occupant discomfort), ease of cleaning and the freeing up of valuable floor space. HCP's products have been used in public buildings such as schools, hospitals, sports halls and classrooms, in industrial scenarios such as warehouses and factories, and in commercial offices and reception areas.

Exploded view of Radiant Heating Panel

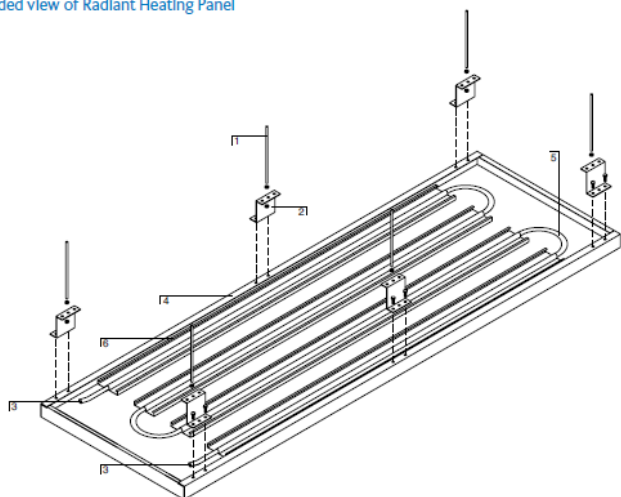

1] Suspension rod 2] Suspension bracket 3] Flow & return pipework 4] Aluminium panel 5] Copper element 6] Aluminium pipe saddle

